

SRS

Spectral Reflectance Sensor

Operator's Manual



METER

METER Group, Inc. USA

14597-04

METER Group, Inc. USA

2365 NE Hopkins Court

Pullman WA 99163

Phone: 509-332-5600

Fax: 509-332-5158

Website: www.metergroup.com

Email: support.environment@metergroup.com or

sales.environment@metergroup.com

METER Group, Inc. USA

©2006-2020

All Rights Reserved

Contents

1	Introduction	1
1.1	Customer Support	1
1.2	About This Manual	2
1.3	Warranty	2
1.4	Seller's Liability	2
2	About SRS	3
2.1	Overview	3
2.2	Specifications	4
3	Theory	6
3.1	Normalized Difference Vegetation Index (NDVI)	6
3.2	Estimating LAI	8
3.3	Fractional Interception of Photosynthetically Active Radiation	8
3.4	Canopy Phenology	10
3.5	Photochemical Reflectance Index (PRI)	11
3.6	Sun-Sensor-Surface Geometry Considerations	12
3.7	Calculating Percent Reflectance from Paired Up and Down Looking Sensors	15
4	Field Installation	19
5	Connecting the SRS	21
5.1	Connecting to METER Data Logger	21
5.2	3.5 mm Stereo Plug Wiring	22
5.3	Connecting to a Non-METER Logger	22
5.4	Pigtail End Wiring	23
6	Communication	25
6.1	SDI-12 Communication	25
7	Understanding Data Outputs	27
7.1	Using METER's Data Loggers	27
7.1.1	Up Looking Sensor Outputs	27
7.1.2	Down Looking Sensor Outputs	27
7.2	Using other data loggers	28

8	Installing the SRS	29
8.1	Attaching and Leveling	29
8.2	Cleaning and Maintenance	29
9	Troubleshooting	31
9.1	Data Logger	31
9.2	Sensors	31
9.3	Calibration	31
10	Declaration of Conformity	33

1 Introduction

Thank you for choosing METER's Spectral Reflectance Sensor (SRS). We designed the SRS for continuous monitoring of Normalized Difference Vegetation Index (NDVI) and/or the Photochemical Reflectance Index (PRI) of plant canopies. We intend for the SRS to be low cost, easily and quickly deployable, and capable of reliable operation over years. NDVI and PRI are used by researchers to monitor canopy biomass, leaf area, phenology (green up and senescence), biomass production, and light use efficiency, among other variables. This manual will help you understand the sensor features and how to use this device successfully.

1.1 Customer Support

If you ever need assistance with your sensor, have any questions or feedback, there are several ways to contact us. METER has Customer Service Representatives available to speak with you Monday through Friday, between 7 am and 5 pm Pacific time.

Note: If you purchased your sensor through a distributor, please contact them for assistance.

Email:

support.environment@metergroup.com or
sales.environment@metergroup.com

Phone:

509-332-5600

Fax:

509-332-5158

If contacting us by email or fax, please include as part of your message your instrument serial number, your name, address, phone, fax number, and a description of your problem or question.

1.2 About This Manual

Please read these instructions before operating your sensor to ensure that it performs to its full potential.

1.3 Warranty

The sensor has a 30-day satisfaction guarantee and a one-year warranty on parts and labor. Your warranty is automatically validated upon receipt of the instrument.

1.4 Seller's Liability

Seller warrants new equipment of its own manufacture against defective workmanship and materials for a period of one year from the date of receipt of equipment.

Note: We do not consider the results of ordinary wear and tear, neglect, misuse, or accident as defects.

The Seller's liability for defective parts shall in no event exceed the furnishing of replacement parts "freight on board" the factory where originally manufactured. Material and equipment covered hereby which is not manufactured by Seller shall be covered only by the warranty of its manufacturer. Seller shall not be liable to Buyer for loss, damage or injuries to persons (including death), or to property or things of whatsoever kind (including, but not without limitation, loss of anticipated profits), occasioned by or arising out of the installation, operation, use, misuse, nonuse, repair, or replacement of said material and equipment, or out of the use of any method or process for which the same may be employed. The use of this equipment constitutes Buyer's acceptance of the terms set forth in this warranty. There are no understandings, representations, or warranties of anykind, express, implied, statutory or otherwise (including, but without limitation, the implied warranties of merchantability and fitness for a particular purpose), not expressly set forth herein.

2 About SRS

2.1 Overview

The SRS are two-band radiometers we designed to measure either incident or reflected radiation in wavelengths appropriate for calculating the Normalized Difference Vegetation Index (NDVI) or the Photochemical Reflectance Index (PRI). They are designed to be an alternative to more complex and costly spectrometers. The SRS sensor comes in four different versions: NDVI-hemispherical (Ni), NDVI-field stop (Nr), PRI-hemispherical (Pi) and PRI-field stop (Pr). The hemispherical versions (Figure 1) are built with Teflon diffusers for making cosine-corrected measurements, with a hemispherical 180° FOV, and are primarily designed for up looking measurements of incident radiation. The field stop versions (Figure 2) have a field of view restricted to 36° (18° half angle) and are designed for pointing downward to measure canopy reflected radiation.

Calculating NDVI or PRI requires knowing both incoming and reflected radiation. Unlike the reflected radiation, the incoming radiation is spatially uniform above the canopy. So, you only need one up facing radiometer to compute the vegetation indices for many down facing radiometers that are within the same general area. The up looking radiometer must be leveled and have a hemispherical field of view.

The SRS is a digital sensor. Its outputs follow the SDI-12 standard. The SRS is best suited for use with METER's data loggers. However, customers can use the SRS with other loggers, such as those from Campbell Scientific.

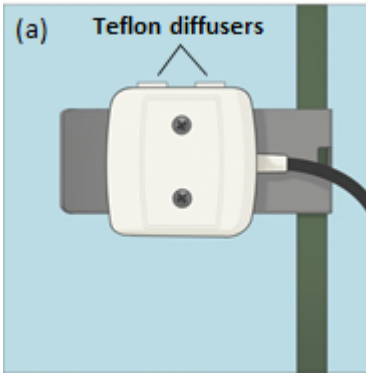

Figure 1: Hemispherical Version

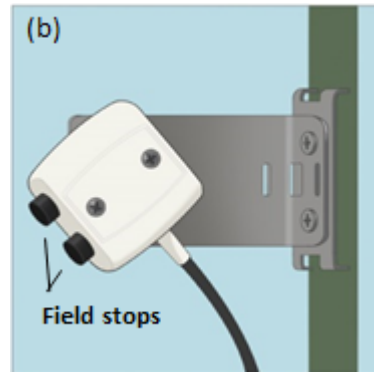

Figure 2: Field Stop Version

2.2 Specifications

Accuracy: 10% or better for spectral irradiance and radiance values

Measurement Time: < 600 ms

NDVI Wavebands: 650 and 810 nm central wavelengths, with 10 nm full width half maximum band widths

PRI Wavebands: 532 and 570 nm central wavelengths, with 10 nm full width half maximum band widths

Field of View: Hemispherical version: 180° full angle, Field stop version: 36° full angle (18° half angle)

Dimensions: 43 x 40 x 27 mm

Weight: 47 g (sensor), 170 g (sensor with 5 m cable)

Power Requirements: 3.6 to 15 V DC, 4 mA (reading, 600 ms) 30 μ A (quiescent)

Operating Temperature: -40 to 50 °C

Connector Types: 3.5 mm (stereo) plug or stripped & tinned lead wires (Pigtail)

Cable Length: 5 m standard

Other Features:

- SDI-12 digital sensor, compatible with METER data loggers and CSI loggers
- In-sensor storage of calibration values
- Four versions
 - Ni - NDVI hemispherical
 - Nr - NDVI field stop
 - Pi - PRI hemispherical
 - Pr - PRI field stop
- NIST traceable calibration to known spectral radiance or irradiance values
- Sensors can be mounted facing up or down, singly or in tandem, leveled or aimed
- Sensor body and electronics are fully sealed from the elements and UV resistant to minimize drift over time

3 Theory

METER designed the SRS to measure NDVI and PRI vegetation indices from plant canopies. We caution users that NDVI and PRI are derived from measurements of radiation reflected from canopy surfaces, and therefore provide only indirect or correlative associations with several canopy variables of interest and should not be treated as direct measurements of these variables.

NDVI has a well-established and long history of use in remote sensing research and ecological applications related to canopy structure. PRI, while showing great promise for quantifying canopy physiological function, is far more experimental with new uses and caveats continually being discovered. While NDVI and PRI can be powerful tools for inferring structure and function of plant canopies, you must take into account their limitations when interpreting the data. Section 3 provides an overview of the theory and discusses some of the uses and limitations of each vegetation index.

3.1 Normalized Difference Vegetation Index (NDVI)

A number of nondestructive methods exist for remotely monitoring and quantifying certain canopy characteristics. Some of those characteristics are: foliar biochemistry and pigment content, leaf area index (LAI, Nguy-Robinson et al., 2012), phenology, and canopy photosynthesis (Ryu et al., 2010). One nondestructive method involves measuring NDVI. The underlying principle of NDVI derives from a well known concept that vegetation reflects light differently in the visible spectrum (400 to 700 nm) compared to the near infrared (> 700 nm).

Green leaves absorb light most strongly in the visible spectrum, especially at red wavelengths, but are highly reflective in the near infrared region (Figure 3). Because bare soil, detritus, stems, trunks, branches, and other non-photosynthetic elements show relatively little difference in reflectance between the visible and near infrared, measuring the difference between reflectance in these two bands can be related to the amount green vegetation in the field of view of a ra-

diometer. See Royo and Dolors (2011) for an extensive introduction to using spectral indices for plant canopy measurements.

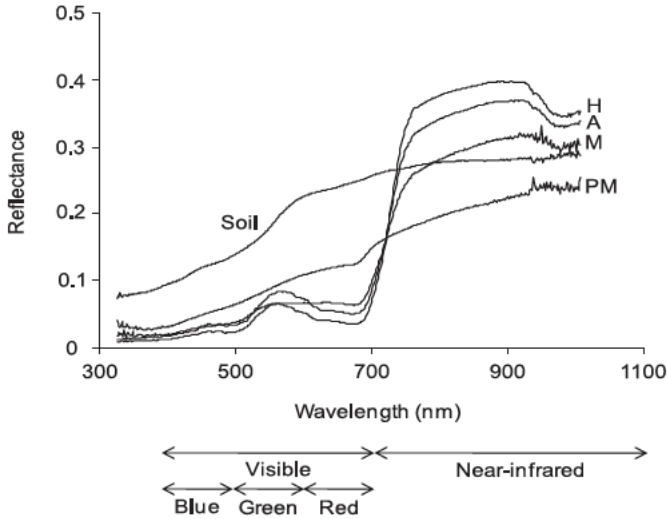

Figure 3: Reflectance spectra for bare soil (Soil) and a healthy wheat crop at various stages of development: heading (H), anthesis (A), milk-grain stage (M), and post maturity (PM). Consider two things about this figure: First, the considerable difference between reflectance spectra from the soil and all stages of plant development. Second, the changes in the visible spectra as the canopy matures and senesces. Figure reproduced with permission from Royo and Dolors (2011).

Calculate NDVI as:

$$NDVI = \frac{\rho_{NIR} - \rho_{red}}{\rho_{NIR} + \rho_{red}} \quad (1)$$

where, ρ_{red} and ρ_{NIR} are percent reflectances in the red and near infrared (NIR). We assume percent reflectance to be the ratio of reflected to incident radiation in the specified waveband. A detailed description of how to calculate reflectances from measured radiation values is provided in equation number 4.

3.2 Estimating LAI

NDVI has been shown to correlate well with green LAI, although the relationship is crop- or canopy-specific. For example, Aparicio et al. (2002) studied NDVI versus LAI in more than twenty different durum wheat genotypes in seven experiments over two years and found the relationship shown in Figure 4. Nguy-Robinson (2012) also studied the behavior of NDVI versus LAI in maize and soybean. Their data suggest a similar relationship between the two crops, but not identical. These relationships have been developed for a wide range of crop and natural canopies and we encourage our customers to seek out the best relationship for their application.

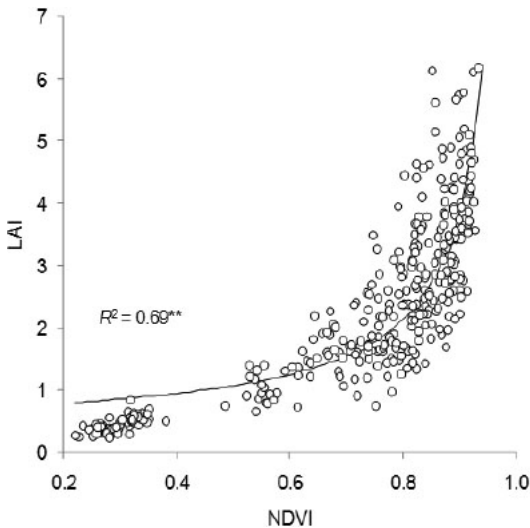

Figure 4: Relationship between leaf area index and NDVI for 20-25 durum wheat genotypes studied over two years in seven different experiments by Aparicio et al. (2002). Values shown were taken at anthesis and milk-grain stage. Used with permission from author.

3.3 Fractional Interception of Photosynthetically Active Radiation

The use of NDVI for determination of leaf area index has limitations. Like many nondestructive techniques (e.g., hemispherical photogra-

phy and ceptometer techniques), the measurement of NDVI becomes less and less sensitive as LAI increases above a certain point (Figure 4). Nguy-Robinson et al. (2012) suggest changes in LAI are difficult to detect when LAI is much greater than $3 \text{ m}^2\text{m}^{-2}$. This should not be surprising considering the spectral measurement being made. NDVI measurements rely on reflected light from leaf surfaces. As the canopy fills and upper leaves begin to cover lower leaves, the leaf area will continue to increase without making a further contribution to reflected radiation. Furthermore, foliar chlorophyll is a very efficient absorber of radiation in red wavelengths so that reflectance from leaves is typically very low in the red region (Figure 3). Therefore, increasing LAI, and thus canopy chlorophyll content, does not substantially change red reflectance beyond a certain point. For these reasons NDVI has limited predictive ability in canopies with high LAI. For some applications, however, NDVI saturation at high LAI may not be as important as it would appear.

Although NDVI may have limited sensitivity when LAI is high, shaded leaves tend to have much less impact on light capture compared to sunlit leaves, and therefore contribute proportionally less to canopy productivity. As a general modeling parameter, an estimate of sunlit leaves may be adequate for estimating photosynthesis and biomass accumulation (i.e., carbon uptake) for some applications. Monteith (1977) proposed the now well-known relationship between biomass accumulation and radiation capture seen in equation 2.

$$A_{n, \text{canopy}} = \epsilon f_s S_t \quad (2)$$

In equation 2, $A_{n, \text{canopy}}$ is the biomass accumulation or carbon assimilation and ϵ is a conversion efficiency often referred to as light use efficiency (LUE). The LUE depends on a variety of factors such as photosynthetic acclimation, physiological stress level, and plant species. f_s is the fractional interception of radiation by the canopy, and S_t is the total incident radiation. The relationship between NDVI and LAI in Nguy-Robinson et al. (2012) and the relation between fractional interception and LAI (Campbell and Norman, 1998) show that NDVI and fractional interception are approximately linearly related (Figure 5). Even when LAI is high, NDVI can provide a good estimate of the fractional interception by green leaves in a canopy; a value that is critical for carbon assimilation models.

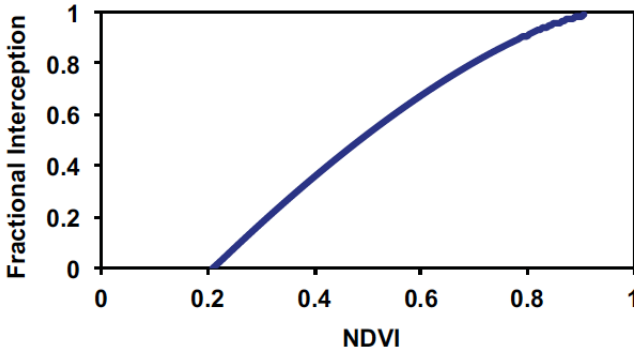

Figure 5: Relationship between fractional canopy interception and NDVI, where NDVI is converted to LAI using Nguy-Robinson et al. (2012). Campbell and Norman (1998) give the relationship between LAI and fractional interception.

3.4 Canopy Phenology

Like all spectral measurements, NDVI is an indirect measurement. Over the years, researchers have correlated NDVI to several parameters of interest, like LAI and f_s , biomass, and canopy productivity, among others. Two of these variables are the focus of Ryu et al. (2010), who used an NDVI sensor, similar to the SRS-NDVI, to measure canopy phenology and associated changes in photosynthesis in an annual grassland over a four year period. Ryu et al (2010). show an exponential relationship between NDVI and canopy photosynthesis, but found that the LAI of grassland never increases above $2.5 \text{ m}^2\text{m}^{-2}$. Ecosystem phenology can also be tracked in the time series data from their NDVI sensor with errors on the order of a few days. It should be noted that they filtered their data by limiting NDVI measurements to a particular sun elevation angle (e.g., sampling under identical sun zenith and azimuth angles from day to day).

3.5 Photochemical Reflectance Index (PRI)

As described above, researchers use NDVI primarily as a proxy for canopy structural variables. Although structural properties are critical, sometimes it is useful to have information about canopy functional properties. For example, estimating gross primary productivity (GPP) of ecosystems is critical for modeling the global carbon balance. The simple model presented in Equation 2 can be used to predict GPP from three variables: incident light (S_t), intercepted light (f_s), and light use efficiency (ϵ). S_t can generally be estimated depending on geographic location and time of day or measured with a PAR sensor or pyranometer. Considering the near linear relationship between NDVI and fractional interception noted above, a simple two-band spectral reflectance sensor like the SRS-NDVI can provide an estimate of f_s . The light use efficiency term (ϵ) remains to be quantified in order to make accurate predictions of GPP.

Gamon et al. (1990, 1992) proposed a dual band vegetation index (similar to the NDVI) that could be used to estimate ϵ . The foundation of the measurement is based on the absorbance of xanthophyll pigments in a fairly narrow spectral region around 532 nm. The xanthophyll cycle signal seen in reflectance at 532 nm has been shown to be well correlated with LUE in many plant species (Gamon et al., 1997).

The Photochemical Reflectance Index (PRI) uses reflectance at 532 nm and is calculated using Equation 3.

$$PRI = \frac{\rho_{532} - \rho_{570}}{\rho_{532} + \rho_{570}} \quad (3)$$

where, ρ_{532} and ρ_{570} are percent reflectances at 532 and 570 nm, respectively.

In addition to LUE, PRI has also been shown to correlate with numerous other physiological variables associated with plant photosynthetic performance from the leaf to the ecosystem levels (Gamon et al., 1992, 1997, 2001). Numerous studies correlate PRI to various ecophysiological variables including the epoxidation state of xanthophyll, maximum photochemical efficiency of photosystem II, effective

quantum yield, maximum photosynthesis rate, electron transport under saturating light, non-photochemical quenching, and chlorophyll to carotenoid content ratio (Sims & Gamon, 2002; Garrity et al., 2011; Garbulsky et al., 2011; Porcar-Castell et al., 2012). Garbulsky et al. (2011) and Porcar-Castell et al. (2012) provide excellent overviews of what has been done with PRI including analyses of PRI correlations with several of these variables at the leaf, canopy, and ecosystem levels. We encourage our customers to use these references as a starting resource.

3.6 Sun-Sensor-Surface Geometry Considerations

It is not uncommon for a time series of NDVI or PRI to contain high amounts of variability due to changing environmental and observation conditions. Spectral reflectance measurements are inherently variable due to radiation source, reflecting surface, and sun-sensor-surface geometry. Sometimes NDVI and/or PRI values exhibit erratic behavior due to changing environmental conditions. Some level of data filtering (e.g., visual inspection for short time series or automated despiking and smoothing algorithms for longer time series) may be required to remove spurious data points, including cleaning up points that result in indeterminate or undefined results from the NDVI or PRI calculation. Consider the NDVI time series shown in Figure 6a. These data were collected from a corn canopy planted in June. The data sampling interval was five minutes. There are several things to notice:

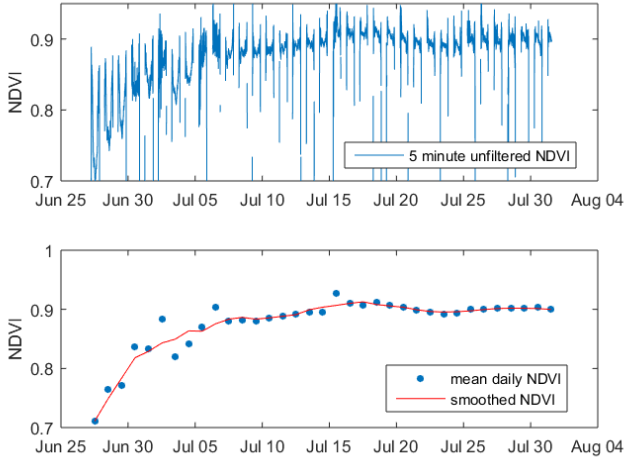

Figure 6: NDVI data collected at five minute intervals from a corn canopy. B) Daily mean NDVI (blue circles) and smoothed daily NDVI (red line), substantially reduce the high frequency variability in the original NDVI time series.

1. Toward the beginning of the time series, NDVI data increase until plateauing in early July, when canopy closure occurred.
2. There is a significant amount of high frequency variability, making it difficult to see this pattern clearly.
3. One source of data variability is due to sun-sensor-surface geometry. A concave diurnal pattern of NDVI is normal, and is caused by the sun moving across the sky each day (Figure 7).

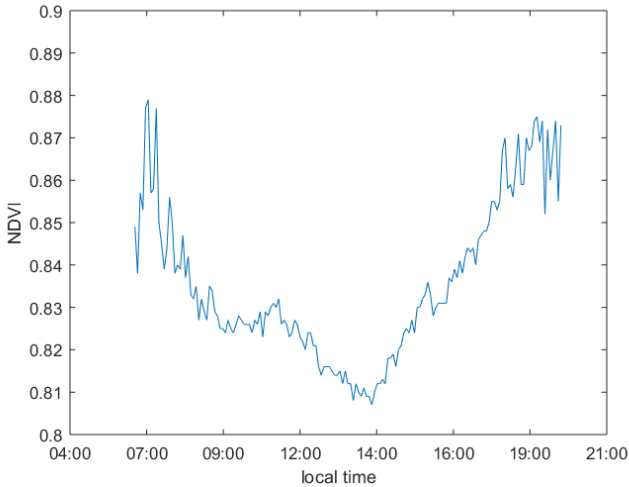

Figure 7: A subset of the data displayed in Figure 6, showing a single day of NDVI data. Notice the concave pattern that is typical in diurnal NDVI measurements. The concave pattern is due to changing sun-sensor-surface illumination geometry throughout the day.

4. Calculating daily averages, using values acquired only during the noon hour, significantly reduces the amount of data variability (Figure 6b). A smoothing algorithm applied to the daily averages reduces variability even further. In this example, data were filtered and averaged by time, but you can also use solar zenith and azimuth angles to filter your data. For example, Ryu et al. (2012) sampled across a consistent solar elevation angle (60) each day, ignoring all other values. Using solar zenith angle as a filter ensures that data from each day are collected under similar sun-sensor-surface illumination conditions.
5. If you are comparing measurements acquired under different sun-sensor-surface configurations (e.g., comparing PRI measurements made during the morning and afternoon), it may be necessary to first calculate a bidirectional reflectance distribution function (BRDF). An empirical BRDF model, derived from NDVI or PRI measurements and canopy-specific param-

eters, can be used to reduce variations that arise from changes in sun-sensor-surface geometry across diurnal time scales. For additional details on BRDF normalization of vegetation index time series, see Hilker et al. (2008).

3.7 Calculating Percent Reflectance from Paired Up and Down Looking Sensors

Equation 1 shows that NDVI is the ratio of the difference to the sum of NIR and red reflectances. Each reflectance value is the ratio of upwelling (down looking sensor) to incident (up looking sensor) radiant flux in each of the wave bands. Calculating this ratio is only possible when measurements of downwelling and upwelling radiation are collected simultaneously under the same ambient conditions. Combining measurements made with sensors located long distances apart is typically not recommended because atmospheric conditions (e.g., cloud cover, aerosols) can be highly variable in space. Reasonable distances between up looking and down looking sensors will depend on the typical radiation environment of a given location.

It is important to arrange paired up looking and down looking sensors to collect data at the same time to account for temporal variability in radiation conditions. In cases where multiple down looking sensors have been deployed within close proximity to each other, it is only necessary to have one up looking sensor. The measurements from the single up looking sensor can be combined with the measurements from each of the down looking sensors to calculate reflectances.

In the event that up looking measurements are not available, rearrangement of the vegetation index equations allows for a rough approximation of the measurements. The following derivation is for NDVI, but similar equations apply to the PRI. If R_n is the reflected NIR radiation from the canopy, R_r is the reflected red radiation, I_n is the incident NIR, and I_r is the incident red, then

$$NDVI = \frac{R_n/I_n - R_r/I_r}{R_n/I_n + R_r/I_r} = \frac{(I_r/I_n)R_n - R_r}{(I_r/I_n)R_n + R_r} = \frac{\alpha R_n - R_r}{\alpha R_n + R_r} \quad (4)$$

Where $\alpha = I_r/I_n$, equation 4 allows the computation of NDVI from just the down facing measurements if you know the ratio of red to NIR spectral irradiance, α . Although not extensively tested, we have found that this ratio ($\alpha = 1.4$ for NDVI bands) can be used as a rough approximation during midday under clear sky conditions. However, we advise that direct measurements of downwelling radiation is more accurate by accounting for any fluctuations in α that occur with changes in atmospheric conditions or across large variations in sun elevation angle.

In the event that you do not want to use the default α value or if measurements from an up facing sensor are not available, it is possible to use a Spectralon panel or similar reflectance standard with a field stop SRS to measure incident irradiance. To measure incident irradiance with a down facing sensor, place a reflectance standard within the field of view of the field stop sensor, making sure that the reflectance panel is uniformly illuminated and that the field of view of the sensor is fully within the area of the reflectance panel. Measurements obtained from field stop sensors pointed at the reflectance panel must be multiplied by π to convert radiance values to irradiance values. Irradiance values can then be used in Equation 4 or to calculate α directly.

References

- Aparicio, N., Villegas, D., Casadesus, J., Araus, J.L., and Royo, C., (2000). Spectral vegetation indices as nondestructive tools for determining durum wheat yield. *Agronomy Journal*, 92: 83-91.
- Aparicio, N.; Villegas, D.; Araus, J.L.; Casadess, J.; Royo, C., (2002). Relationship between growth traits and spectral reflectance indices in durum wheat. *Crop Science*, 42: 1547-1555.
- Campbell, G.S. and Norman, J.M., (1998). An Introduction to Environmental Biophysics. Springer-Verlag. New York.
- Gamon, J.A., Field, C.B., Bilger, W., Bjorkman, O., Fredeen, A.L., Penuelas, J., (1990). Remote sensing of the xanthophylls cycle and

chlorophyll fluorescence in sunflower leaves and canopies. *Oecologia*, 85: 1-7.

Gamon, J.A., Peuelas, J., Field, C.B., (1992). A narrow-waveband spectral index that tracks diurnal changes in photosynthetic efficiency. *Remote Sensing of Environment*, 41: 35-44.

Gamon, J. A., Serrano, L., Surfus, J. S., (1997). The photochemical reflectance index: an optical indicator of photosynthetic radiation use efficiency across species, functional types, and nutrient levels. *Oecologia*, 112: 492-501.

Gamon, J. A., Field, C. B., Fredeen, A. L., Thayer, S., (2001). Assessing photosynthetic downregulation in sunflower stands with an optically based model. *Photosynthesis Research*, 67: 113-125.

Garbulsky, M.F., Peuelas, J., Gamon, J., Inoue, Y., Filella, Y. (2011). The photochemical reflectance index (PRI) and the remote sensing of leaf, canopy and ecosystem radiation use efficiencies: A review and meta-analysis. *Remote Sensing of the Environment*, 115: 281-297.

Garrity, S.R., Vierling, L.A., Bickford, K., (2010). A simple filtered photodiode instrument for continuous measurement of narrowband NDVI and PRI over vegetated canopies. *Agricultural & Forest Meteorology*, 150: 489-496.

Garrity, S. R., Eitel, J. U. H., Vierling, L. A., (2011). Disentangling the relationships between plant pigments and the photochemical reflectance index reveals a new approach for remote estimation of carotenoid content. *Remote Sensing of Environment*, 115: 628-635.

Hilker, T., Coops, N. C., Hall, F. G., Black, T. A., Wulder, M. A., Nesic, Z., Krishnan, P., (2008). Separating physiologically and directionally induced changes in PRI using BRDF models. *Remote Sensing of Environment*, 112: 2777-2788.

Monteith, J.L., (1977). Climate and the efficiency of crop production in Britain. *Philosophical Transactions Royal Society of London B*,

281: 277-294.

Nguy-Robertson, A., Gitelson, A., Peng, Y., Via, A., Arkebauer, T., and Rundquist, D., (2012). Green leaf area index estimation in maize and soybean: Combining vegetation indices to achieve maximal sensitivity. *Agronomy Journal*, 104: 1336-1347.

Porcar-Castell, A., Garcia-Plazaola, J. I., Nichol, C. J., Kolari, P., Olascoaga, B., Kuusinen, N., Fernandez-Marn, B., Pulkkinen, M., Juurola, E., Nikinmaa, E., (2012). Physiology of the seasonal relationship between the photochemical reflectance index and photosynthetic light use efficiency. *Oecologia*, 170: 313-323.

Royo, C. and Villegas, D., (2011). Field Measurements of Canopy Spectra for Biomass Assessment of Small-Grain Cereals, Biomass - Detection, Production and Usage, Darko Matovic (Ed.), ISBN: 978-953-307-492-4, InTech, Available from: <http://www.intechopen.com/books/biomass-detection-production-and-usage/field-measurements-of-canopy-spectra-for-biomass-assessment-of-small-grain-cereals>.

Ryu, Y., Baldocchi, D.D., Verfaillie, J., Ma, S., Falk, M., Ruiz-Mercado, I., Hehn, T., Sonnentag, O., (2012). Testing the performance of a novel spectral reflectance sensor, built with light emitting diodes (LEDs), to monitor ecosystem metabolism, structure and function. *Agricultural & Forest Meteorology*, 150: 1597-1606.

Sims, D. A., Gamon, J. A., (2002). Relationships between leaf pigment content and spectral reflectance across a wide range of species, leaf structures and developmental stages. *Remote Sensing of Environment*, 81: 337-354.

4 Field Installation

The SRS is designed to be light weight, weatherproof, consume low power, and have a small size so that it can be deployed virtually anywhere with relative ease. Because the SRS measures incident and reflected radiation it must be mounted above the plant canopy. For example, the SRS can be mounted to a post, pole, tripod, tower, or other similar infrastructure that extends above the canopy. When measuring incident radiation with a hemispherical view SRS, be sure that the sensor's view of the sky is unobstructed. This is easiest done by placing the sensor above the canopy, however, it may also be achieved by placing the hemispherical sensor in a large canopy gap or forest clearing. Field stop sensors should also generally be mounted above a canopy, but there may be instances where an oblique or side-view of a canopy is more practical than trying to get the sensor above the top of the canopy.

The field stop and hemispherical versions can both be used to quantify canopy reflected radiation. The correct choice of sensor will depend on the objectives of the study. The hemispherical sensor has a ground instantaneous field of view (GIFOV) of 180° (full angle), and will do a better job of averaging reflected radiation over a broad area. When using hemispherical view sensors in a down-facing orientation, extreme care should be taken to mount the sensor perfectly horizontal so that the sensor does not "see" any sky above the horizon. The field stop sensor can be aimed at a particular spot or have a particular orientation, giving the user more control over what portion of the canopy is being measured. When using the field stop sensor in an off-nadir orientation, the user should be careful that the sensor is not pointed above the horizon.

For most applications the field stop SRS is the most appropriate sensor for acquiring down-facing measurements because it allows for more control of the measurement area. For example, in an open canopy woodland, the field stop sensor can be directed at a tree

rather than the vegetation in the inter-spaces. The GIFOV of a field stop SRS that is mounted in the nadir position (i.e., looking straight down) is determined by two factors: the angular field of view (which is fixed at 18° (half angle)) and the height of the sensor above the canopy.

$$GIFOV = 2 * (\tan(18) * h) \quad (5)$$

where h is the height of the sensor above the canopy. Consider a sensor mounted 2 m above a canopy. The GIFOV would be $2 * (\tan(18) * 2)$, which equals a 1.3 m diameter circle.

If the field stop sensor is pointed off-nadir (no longer facing straight down) then the GIFOV becomes elliptical. When using the SRS in an off-nadir view angle, be sure that the field of view does not go above the horizon. For help in calculating the FOV, you can use the simple calculator from Apogee found at:

<https://www.apogeeinstruments.com/irr-calculators/>

Note: You should use the 18 degree half angle in the calculation

5 Connecting the SRS

5.1 Connecting to METER Data Logger

The SRS is most easily used with METER's data loggers. SRS sensors can also be used with other SDI-12 enabled data loggers, such as those from Campbell Scientific, Inc. The SRS requires an excitation voltage in the range of 3.6 to 15 volts.

To download data to your computer from a METER logger, you will need to install one of our Utility programs or other METER software on your computer. Make sure you have the latest logger or data reader firmware to support your SRS sensor.

Note: Please check your software version to ensure it will support the SRS. To update your software to the latest versions, please visit METER's website at <http://www.metergroup.com>.

To use the SRS with your METER data logger, simply connect the stereo plug to one of the ports on the data logger and use either our Utility application or other METER software software to configure that port for the SRS and set the measurement interval. See data logger manual and quick start guide for more instructions.

METER data loggers have a threshold logging frequency. When you set the logging interval to greater than this threshold on any METER logger, reported readings are automatically averaged using data sampled from the sensor at the threshold intervals. Users need to be cautious when choosing a sampling interval with SRS sensors connected to a METER logger, so that the averaging feature does not result in erroneous measurement. For example, if you desire only one reading per day and you select 24 hours as the measurement interval, then each 24 hour reading will be an average of values recorded over the previous 1,440 minutes, including periods during the night. To avoid such errors, we recommend you log data from the SRS sensors more frequently (e.g. 5-15 minutes), even if you are not using all logged data.

If customers require logging intervals shorter than our logging threshold, then they must use a Campbell Scientific or similar logger capable of recording data at the desired frequency.

5.2 3.5 mm Stereo Plug Wiring

The SRS for METER loggers ships with a 3.5 mm stereo plug connector. The stereo plug allows for rapid connection directly to METER's data loggers. Figure 8 shows the wiring configuration for this connector.



Figure 8: 3.5 mm Stereo Plug Wiring

5.3 Connecting to a Non-METER Logger

Customers may purchase the SRS for use with non-METER data loggers. These sensors typically come configured with stripped and tinned (pigtail) wires for use with SDI BUS terminals. Refer to your particular logger manual for details on wiring. Our integrator's guide gives detailed instructions on connecting the SRS to non-METER loggers. Please visit <http://www.metergroup.com> for the complete Integrator's guide.

5.4 Pigtail End Wiring

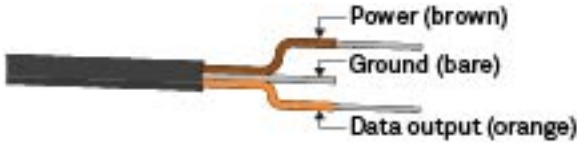

Figure 9: Pigtail End Wiring

Note: Some SRS sensors may have the older Decagon wiring scheme where the power supply is white, the digital out is red, and the bare wire is ground.

Connect the wires to the data logger as Figure 10 shows. Connect the supply wire (brown) to the excitation, the digital out wire (orange) to a digital input, and the bare ground wire to ground.

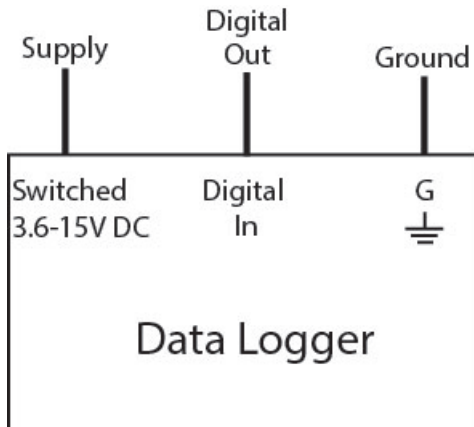

Figure 10: Pigtail End Wiring to Data Logger

Note: The acceptable range of excitation voltages is from 3.6 to 15 VDC. If you wish to read the SRS with the Campbell Scientific Data Loggers, you will need to power the sensors off of a 12 V or switched 12 V port.

If your SRS is equipped with the standard 3.5 mm plug, and you

wish to connect it to a non-METER data logger, use one of the following two options.

Option 1

1. Clip off the stereo plug connector on the sensor cable
2. Strip and tin the wires.
3. Wire it directly into the data logger.

This option has the advantage of creating a direct connection and minimizes the chance of the sensor becoming unplugged. However, it then cannot be easily used in the future with a METER readout unit or data logger.

Option 2

Obtain an adapter cable from METER.

The adapter cable has a connector for the stereo plug connector on one end and three wires (or pigtail adapter) for connection to a data logger. The stripped and tinned adapter cable wires have the same termination as in Figure 10; the brown wire is excitation, the orange is output, and the bare wire is ground.

Note: Be extra careful to secure your stereo to pigtail adapter connections to ensure that sensors do not become disconnected during use.

6 Communication

The SRS communicates using SDI-12 and DDI Serial protocols. This chapter discusses the specifics of SDI-12 Communication. For more information, please visit <http://www.metergroup.com> for an Integrator's guide that gives more detailed explanations and instructions.

6.1 SDI-12 Communication

The SRS communicates using the SDI-12 and DDI Serial protocols, a three-wire interface where all sensors are powered (brown wire), grounded (bare wire) and communicate (orange wire) on shared wires (for more info, go to [our Knowledge Base article on SDI-12](#)).

The SDI-12 protocol requires that each sensor have a unique address when connected to the same digital port. The SRS comes from the factory with an SDI-12 address of 0. To add more than one SDI-12 sensor to a system, the sensor address must change. Address options include 0-9, A-Z, a-z. There are two ways to set the SDI-12 sensor address. The best and easiest is to use METER's ProCheck (if the option is not available on your ProCheck, please upgrade to the latest version of firmware).

Campbell Scientific data loggers, like the CR10X, CR1000, CR3000, among others, also support SDI-12 Communication. Direct SDI-12 communication is supported in the "Terminal Emulator" mode under the "Tools" menu on the "Connect" screen. Detailed information on setting the address using CSI data loggers can be found on our website at <http://www.metergroup.com>.

The sensor can be powered using any voltage from 3.6 to 15 VDC. The SDI-12 protocol allows the sensors to be continuously powered, so the power (brown wire) can be connected to a continuous 12 VDC source. However, the sensor can also be used with a switched 12 V source. This can help reduce power use (although the SRS uses very little power, 0.03 mA quiescent) and will allow the sensor array to be reset if a problem arises.

Reading the SRS in SDI-12 mode using a CSI datalogger requires a function call. An example program from CRBasic can be found on our website at <http://www.metergroup.com>.

7 Understanding Data Outputs

7.1 Using METER's Data Loggers

Each SRS sensor generates multiple outputs when connected to a METER data logger. The exact outputs will in part depend on how many and what type of SRS sensors are attached to the data logger. All SRS sensors are equipped with an internal tilt sensor. The orientation of the SRS, and therefore the tilt sensor, will determine the output from each sensor.

7.1.1 Up Looking Sensor Outputs

For any hemispherical sensor oriented in the uplooking position, outputs will include the calibrated spectral irradiance ($\text{W m}^{-2} \text{nm}^{-1}$) and α , where α is the ratio of 650 nm to 810 nm for NDVI sensors and 570 nm to 532 nm for PRI sensors. See Equation 4 for further details on α .

7.1.2 Down Looking Sensor Outputs

When hemispherical or field stop sensors are mounted in a down-looking orientation, outputs include the calibrated spectral radiance ($\text{W m}^{-2} \text{nm}^{-1} \text{sr}^{-1}$) of each band and either NDVI or PRI. If both up looking and down looking sensors of the same variety (e.g., up looking hemispherical NDVI and down looking field stop NDVI) are connected to the same data logger then α from the up looking sensor is combined with the spectral radiance values from the down looking sensor to calculate the vegetation index, using Equation 4. In the event that only down looking sensors are connected to a data logger, then either the default or the user-specified static α value, is used to calculate the vegetation index. Based on observations collected near Pullman, WA (46°45'0"N, 117°09'6"W), default α values have been set to 0.98 and 1.86 for PRI and NDVI, respectively. Note that actual values of α will change depending on atmospheric conditions and sun angle, so users are encouraged to measure α with an up looking hemispherical sensor. In the event that nearby up looking and

down looking sensors are connected to different data loggers, you can export tabular data as Excel files and manually combine α from the up looking sensor with the spectral radiance values from the down looking sensor to calculate NDVI or PRI.

When manually calculating NDVI or PRI, the manually calculated values may not perfectly match the NDVI or PRI values calculated by Em50 series data loggers. At high radiation intensities (mid-day), when spectral reflectance indices are most useful, the calculated values will be very close. But, at lower radiation intensities, rounding differences caused by the data logger data storage scheme become significant, and will lead to noticeable differences between manually calculated and data logger calculated NDVI and PRI. In many cases, spectral reflectance data during low intensity periods (low sun angles) are not as meaningful as those at higher intensities, but if data from low radiation intensity periods are desirable, manual calculation of the spectral reflectance index will result in best possible precision. Note that these differences should not be present in EM60, ZL6, and future data logger offerings from METER. Contact METER Support for more details support.environment@metergroup.com.

7.2 Using other data loggers

When connected to non-METER data loggers (e.g., Campbell Scientific) sensors will output the calibrated spectral irradiance or radiance from each band and an orientation value from the tilt sensor. Spectral irradiance and radiance are output as radiant fluxes (in $\text{W m}^{-2} \text{nm}^{-1}$ or $\text{W m}^{-2} \text{nm}^{-1} \text{sr}^{-1}$) for the shorter and then the longer wavelength sensor. Tilt sensor readings are output as a single value between 0 and 2, with 0 indicating an indeterminate orientation, 1 indicating a down facing orientation, and 2 indicating an up facing orientation. Additional information about using the SRS with non-METER data loggers can be accessed at www.metergroup.com. For additional information about connecting your SRS to non-METER data loggers, see Section 5.3.

8 Installing the SRS

8.1 Attaching and Leveling

The SRS comes with a variety of mounting hardware, allowing it to be mounted on poles, tripods, towers, etc. The mounting hardware allows for vertical adjustment and orientation on the pole and allows for sensor tilt. Up-facing sensors have Teflon diffusers and measure radiation from the entire upper hemisphere. The sensor therefore needs to be leveled and mounted in a location where it will not be shaded and has an unobstructed view of the sky.

For down-facing sensors, the SRS can be mounted any distance from the canopy, but it is important to keep in mind that the influence of individual plants on the reading increases as the sensor gets closer to the canopy. Distance from the canopy also determines the size of the SRS sample area (Equation 5)

You may use hemispherical sensors in a down facing orientation, but make sure to mount them facing directly down so they are not "seeing" sky. The influence of the mounting infrastructure and sky can be avoided by using field stop radiometers. Field stop sensors average over just the area within the field of view where you aimed them. Assure that the area they see is representative and carefully choose the view angle and azimuth. When the view angle is directly away from the sun the sensor sees mostly sunlit leaves. If it points perpendicular to the sun rays the sensor will see an increased fraction of shadow.

Note: Field stop sensors are intended for measuring canopy-reflected radiation and should not be mounted in an up facing orientation.

8.2 Cleaning and Maintenance

Optical surfaces need to be kept clean and free from contaminants. We recommend that you occasionally inspect the Teflon diffusers and field stop cavities to make sure that they are free from dust, insect nests, bird droppings or other debris. The Teflon diffusers can be

cleaned with a soft, damp cloth. Field stops can be cleaned with compressed air or cotton swabs. Do not use any type of volatile solution when cleaning the field stops since they can damage the optical interference filters. Outer surfaces of your SRS can be cleaned a soft damp cloth as necessary. In the event that your SRS optics become extremely soiled it may be necessary to return to the factory for cleaning and re-calibration. See section 9.3 for more details on SRS calibration.

9 Troubleshooting

Any problem with the SRS will most likely manifest as failed communication or erroneous readings. Before contacting METER about the sensor, please check these troubleshooting steps.

9.1 Data Logger

1. Check to make sure the connections to the data logger are both correct and secure.
2. Ensure that your data logger batteries are not dead or loose.
3. Check the configuration of your data logger to make sure you have selected the correct SRS version (NDVI or PRI, “i” or “r”).
4. If using METER loggers make sure that you are using the correct versions of logger firmware and software.

9.2 Sensors

1. Ensure that you install the sensors according to the “Installation” section of this manual.
2. Check sensor cables for nicks or cuts that could cause a malfunction.
3. Check the sensor wavelength intensity results outside or under a bright light. NDVI or PRI calculations may give no data or erroneous data at low intensities.

9.3 Calibration

METER Group calibrates the Spectral Reflectance Sensor against a NIST traceable transfer standard. Details about your sensor calibration are available upon request. We have a recalibration service available and recommend that you send in your SRS sensors for recalibration annually. Contact METER to obtain a Return Material Autho-

rization (RMA) form to send your sensor in for recalibration. Call or email METER at (509)332-5600 or support.environment@metergroup.com to arrange for a RMA, or to obtain your sensor calibration information.

10 Declaration of Conformity

Application of Council Directive:	2004/108/EC and 2011/65/EU	
Standards to which conformity is declared:	EN61326-1:2013	and EN550581:2012
Manufacturer's Name:	METER Group, Inc. USA 2365 NE Hopkins Ct. Pullman, WA 99163 USA	
Type of Equipment:	Spectral Reflectance Sensor	
Model Number:	SRS	
Year of First Manufacture:	2013	

This is to certify that the SRS Spectral Reflectance Sensor, manufactured by METER Group, Inc. USA, a corporation based in Pullman, Washington, USA meets or exceeds the standards for CE compliance as per the Council Directives noted above. All instruments are built at the factory at METER and pertinent testing documentation is freely available for verification.

Index

Calibration, 31
CE Compliance, 33
Cleaning, 29
Connecting Sensors
 Non-METER Logger, 22
Connecting the Sensors, 21
Contact Information, 1
Customer Support, 1

Declaration of Conformity, 33

Email, 1

Field Installation, 19
Fractional Interception, 8

Installation, 29

Leaf Area Index(LAI), 6

NDVI, 6

Phenology, 10
Photochemical Reflectance Index,
 1
Photosynthesis, 10
Pigtail End Wiring, 23

SDI-12 Communication, 25
Seller's Liability, 2
Specifications, 4
Stereo Wiring 3.5 mm, 22

Troubleshooting, 31

Warranty, 2